

# C O I N - P L U S      C H

## HOPPER CONTROL BOARD

---

**Simple to connect:**

Single standard connection to coin mechanism;  
 Simple connection to optional LED display;  
 Simple screw connections to power, external lamps and coin hopper.

**Manual credit button on-board.**

**External manual credit facility.**

**Coin counter output for audit and metering.**

**Optional relay output.**

**Optional attract mode.**

**Full control of Electronic Coin Mechanism**

**Lamp:**

ON- indicates machine "ready",  
 OFF - indicates machine "out-of-service";  
 FLASH - indicates more coins are required.

**Full control of Coin Mechanism Coin Inhibit:**

When the machine is busy coins can be rejected;  
 Individual coin types can be permanently rejected.

**Extensive range of coin hopper payout values:**

UK coins 1p, 2p, 5p, 10p, 20p, 50p, £1, £2 and eight different value tokens may be paid out.

**Ready for the new £2 coin:**

The £2 coin can be either accepted or paid out.

**Accumulator bonus:**

three bonus plans;  
 five bonus levels.

**Coin bonus facility for any combination of coins.**

**Interface to two or four digit LED displays:**

Ability to display the amount of money entered since the last credit (the partial credit);  
 Ability to display number of credits waiting to be issued;

**Continuous self test;**

Invalid configuration detection with fail-safe and warning indicator;

---

### *Features*

- Drives Asahi Seiko SH-series, WH-series, SA-595, SG-595 and other hoppers fitted with the DCMB9101A brake electronics;
- Drives Coin Controls Universal Hoppers marks II, III and IV;
- Drives Deltronics Ticket Dispensers such as the DL-1275 (with RELAY option fitted);
- Supports coin mechanism anti-strimming protection;
- Bonus table resets 25 seconds after last coin is entered;
- Contact factory for other currencies;
- Never loses partial credit.

User (field programmable) options	Factory set options
Hopper payout coin value (16 settings)	Currency
bonus plan (no bonuses or 3 settings)	Optional two or four digit LED display which can display credits or accumulated cash
Coin bonus selection (ON or OFF)	Number of bonus credits in coin bonus mode
	Attract mode

The Hopper Payout and Bonus Tables shown here are for UK coins 1p, 2p, 5p, 10p, 20p, 50p, £1, £2. Contact the factory for other coinsets and currencies.

### Switch settings

Function	Sw1	Sw2	Sw3	Sw4
Automatic Payout	OFF			
Manual Payout	ON			
No bonuses		OFF	OFF	OFF
Use coin bonuses		ON	OFF	OFF
Use bonus plan 1		OFF	ON	OFF
Use bonus plan 2		OFF	OFF	ON
Use bonus plan 3		OFF	ON	ON

Hopper payout value	Sw5	Sw6	Sw7	Sw8
Disable Hopper	OFF	OFF	OFF	OFF
1p coin	ON	OFF	OFF	OFF
2p coin	OFF	ON	OFF	OFF
5p coin	ON	ON	OFF	OFF
10p coin	OFF	OFF	ON	OFF
20p coin	ON	OFF	ON	OFF
50p coin	OFF	ON	ON	OFF
£1 coin	ON	ON	ON	OFF
£2 coin	OFF	OFF	OFF	ON
30p token	ON	OFF	OFF	ON
40p token	OFF	ON	OFF	ON
60p token	ON	ON	OFF	ON
70p token	OFF	OFF	ON	ON
80p token	ON	OFF	ON	ON
90p token	OFF	ON	ON	ON
£1.50 token	ON	ON	ON	ON

### Bonus Table

Hopper Payout	Bonus Plan	Number of Bonus Credits given at:	50p	£1	£2	£3	£4
1p	1	1	2	5	8	11	
	2	1	3	7	11	15	
	3	2	5	12	18	25	
2p	1	1	1	3	5	7	
	2	1	2	5	8	11	
	3	2	4	10	15	21	
5p	1	1	1	3	5	7	
	2	1	2	6	8	13	
	3	2	4	9	14	19	
10p	1	0	1	2	4	5	
	2	1	2	5	8	11	
	3	1	3	7	11	15	
20p	1	0	0	1	2	3	
	2	0	1	2	4	6	
	3	0	1	3	6	7	
50p	1	0	0	1	2	4	
	2	0	1	2	3	5	
	3	0	2	3	5	8	
£1	1	0	0	2	3	4	
	2	0	1	3	4	7	
	3	0	2	4	6	9	
£2	1	0	0	1	2	3	
	2	0	1	2	4	5	
	3	0	1	3	5	7	
30p token	1	0	0	1	2	3	
	2	0	0	1	3	5	
	3	0	0	2	4	6	
40p token	1	0	0	0	1	2	
	2	0	0	1	2	3	
	3	0	0	1	3	5	
60p token	1	0	0	0	1	2	
	2	0	0	1	1	3	
	3	0	0	1	2	4	
70p token	1	0	0	0	1	2	
	2	0	0	1	1	3	
	3	0	0	1	2	4	
80p token	1	0	0	0	1	2	
	2	0	0	1	1	3	
	3	0	0	1	2	4	
90p token	1	0	0	0	0	1	
	2	0	0	0	1	1	
	3	0	0	0	1	2	
£1.50 token	1	0	0	0	0	1	
	2	0	0	0	1	1	
	3	0	0	0	1	2	

### Drawing

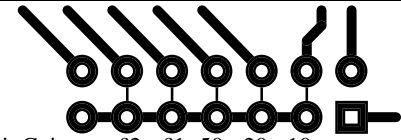
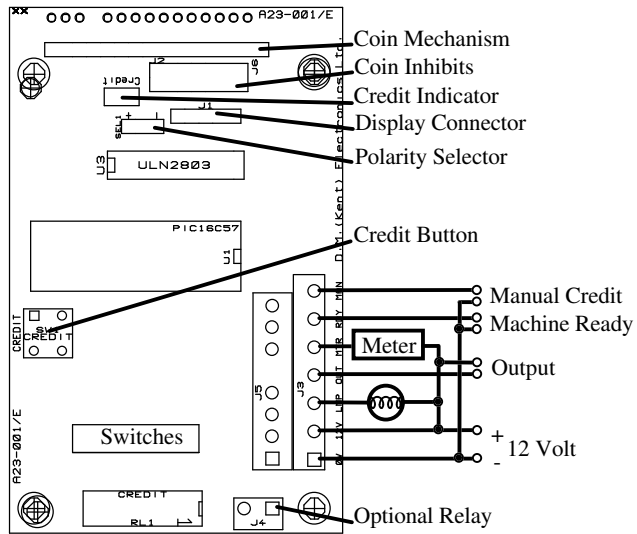

Polarity Selection	
+	Mars Electronics International: CF, ME, MS Series Coin Controls: C220, C435 Series
-	Asahi Seiko: all models (A23-004/A required) Coin Controls: C120 Series (interface required)

## Suggested Wiring - Asahi Seiko hoppers

The Asahi Seiko hoppers require the following power supply:

- 1) 24 Volt regulated supply rated at 1 Amp for the hopper motor;
- 2) 12 Volt regulated supply rated at 30 mA for the logic electronics.
- 3) 5 Volt regulated supply rated at 30 mA for the optical coin detect sensor.

The COIN+CH hopper control board and associated equipment requires the following power supply:

- 1) 12 Volt regulated supply rated at 1 Amp for the COIN+CH, Coin validator, electro-mechanical counter and LED display.

The following wiring pattern is recommended for the SH400 hopper used in standard designs. Please contact the factory for specific requirements.

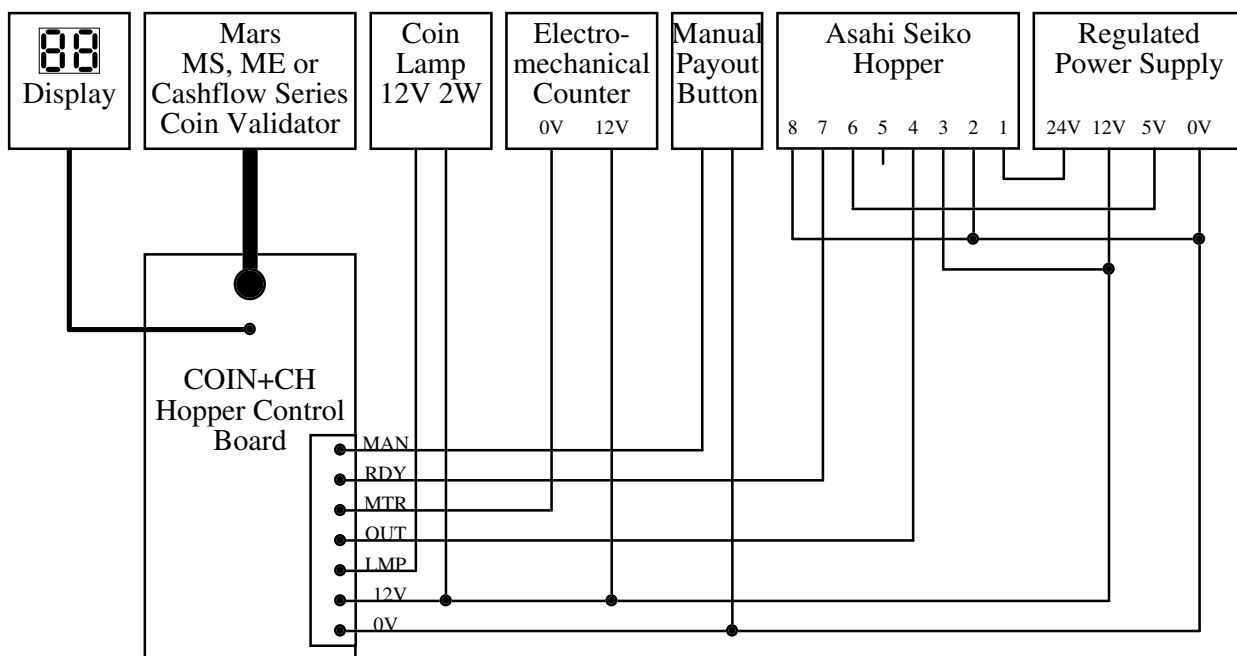

The following wiring pattern is recommended for the SA595 hopper with mounting plate used in standard designs. Please contact the factory for specific requirements.

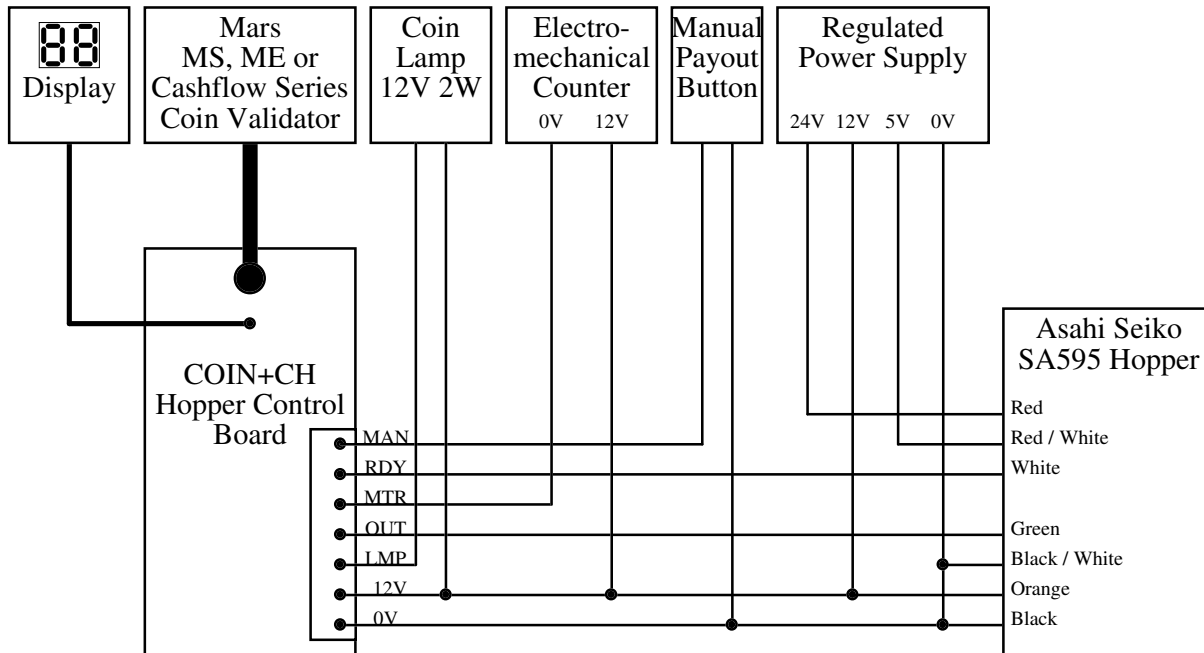

**Please Note:** In some environments the 5 Volts supply required by the Asahi Seiko Hopper will not be readily available. D.M. (Kent) Electronics can supply 12 Volt to 5 Volt converters to generate the 5 Volt supply from the 12 Volt supply. Please contact the factory for details.

## Suggested Wiring - Coin Controls Universal Hopper

The Coin Controls Universal Hopper require the following power supply:

- 1) 24 Volt regulated supply rated at 1 Amp for the hopper motor;
- 2) 12 Volt regulated supply rated at 1 Amp for the logic electronics.

The COIN+CH hopper control board and associated equipment requires the following power supply:

- 1) 12 Volt regulated supply rated at 1 Amp for the COIN+CH, Coin validator, electro-mechanical counter and LED display.

The following wiring pattern is recommended for standard designs. Please contact the factory for specific requirements.

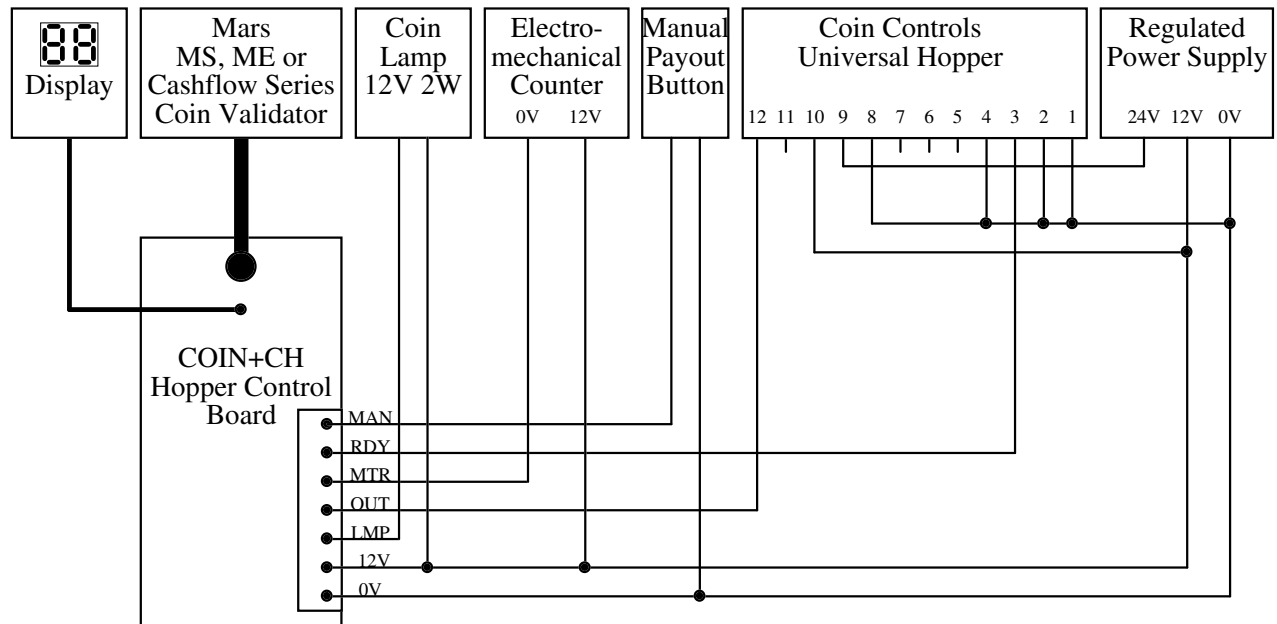

**Please Note:** If the 24 Volt supply is applied to the hopper without the 12 Volt supply also being connected it is possible that the hopper will operate and dump its contents. If the 12 Volt and 24 Volt supplies are fused separately action should be taken to avoid this situation if the 12 Volt fuse should fail. For further information and advice please contact the factory.

## Suggested Wiring - Ticket dispensers

The Deltronic Labs. Inc. ticket dispensers require the following power supply:

- 1) 12 Volt regulated supply rated at 1 Amp for the logic electronics.

The COIN+CH hopper control board and associated equipment requires the following power supply:

- 1) 12 Volt regulated supply rated at 1 Amp for the COIN+CH, Coin validator, electro-mechanical counter and LED display.

The following wiring pattern is recommended for standard designs. Please contact the factory for specific requirements.

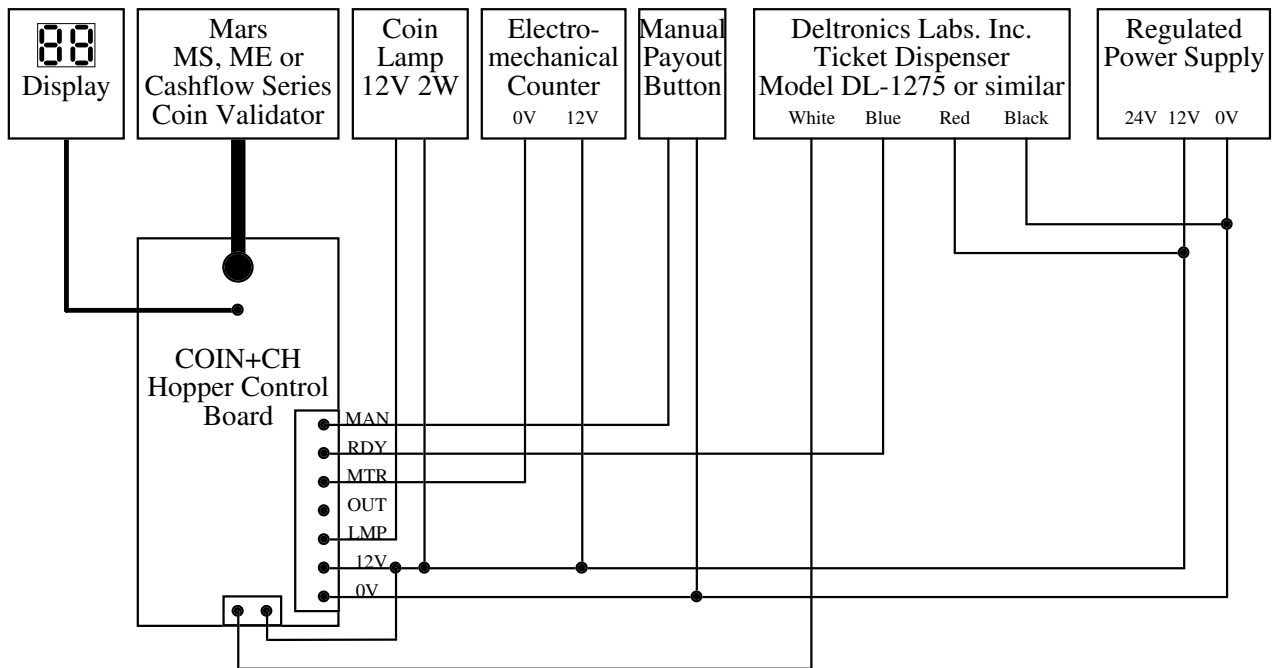

**Please Note:** In order to drive Deltronic Labs. Inc. ticket dispensers the COIN+CH must be fitted with its relay option. Please contact the factory for details and ensure that the board is ordered with the relay option.

## *Operational Notes*

- In Manual Payout Mode (SW-1=ON) with a 2-digit display fitted, The COIN+CH will not hold more than 100 coins waiting to be paid out. If more than 100 coins are to be paid out then the coin validator will be inhibited from accepting more coins, the display will show EC (error in coins) and payout will start automatically. When the number of coins left to be paid has been reduced to 98 payout will stop and the manual payout button will become active;
- In Manual Payout Mode (SW-1=ON) with either no display or a 4-digit display fitted, The COIN+CH will not hold more than 10000 coins waiting to be paid out. If more than 10000 coins are to be paid out then the coin validator will be inhibited from accepting more coins, the display will show ECEC (error in coins) and payout will start automatically. When the number of coins left to be paid has been reduced to 9998 payout will stop and the manual payout button will become active;
- In Manual Payout Mode (SW-1=ON) the coin validator will be inhibited from accepting more coins while the Payout Button is held down;
- The COIN+CH does not detect hopper empty conditions. It will wait 1½ seconds for a coin to payout from the hopper before entering its hopper jam protection mode. It will start and stop the hopper indefinitely trying to free any hopper jam;
- The minimum time delay between hopper payouts is 1½ seconds;